

Description

EC Pot S is intended for controlling the speed of EC-motors, frequency inverters or other equipment with a 10V reference output and a 0-10V control signal.

The speed is adjusted on the knob on the front.

EC Pot S only requires connection to the 10V output and signal wires of the EC-motor.

It is possible to also use the EC Pot S to switch on/off the power for the EC-motor. This requires that the supply power is going through the potentiometer. Please refer to below drawing of terminal connection. Using this function you turn off the power to the EC-motor by turning the knob counter clockwise till you hear a small click as the potentiometer switches off the power (knob in 'off' position).

Warning

 ESD-Sensitive when the lid is removed. Make sure to be ESD discharged before installation.

Mounting

Must be mounted on a non-vibrating surface in a non-condensing environment. Do not place in direct sunlight and must be protected from all types of UV-light.

Terminal Connection

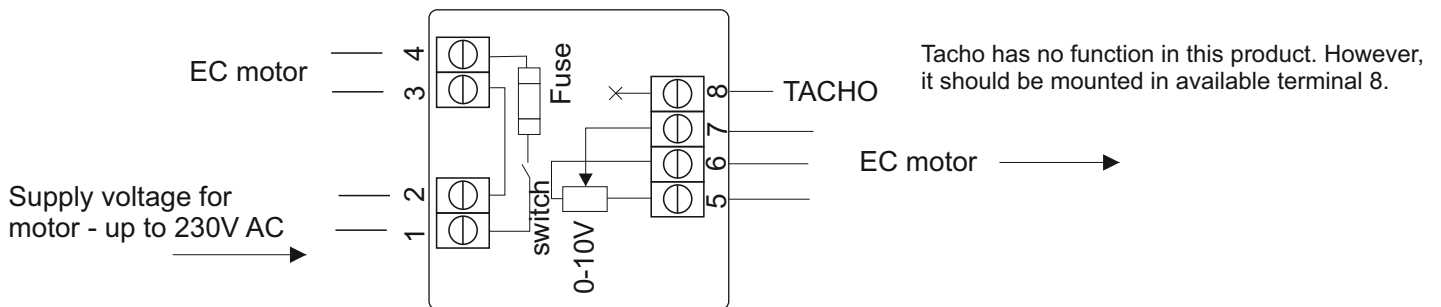

Adjustment

Minimum speed can be adjusted on an internal trimmer within the box.

It is adjusted, so the motor has the speed required when the knob is turned to minimum just before the click.

After having finished the adjustment it is recommended to control that the motor starts up smoothly when the knob is turned from 'off' to minimum. If the motor is turned on but not running the motor might get damaged.

Technical Specifications

Enclosure: Depending on model. 41640: IP40 / 41840: IP54
 Dimensions (HxWxD): Depending on model. 41640: 85x85x54mm / 41840: 80x82x54mm

Build-in switch: max. 230V 6A
 Internal fuse: 6.3A

Terminal 5-8:

Supply Voltage: 10V DC, min 1.1mA
 input impedance: 10VDC:500 - 600 Kohm
 Output voltage: 0-10V DC
 Output Load: Depending on 10V DC supply Max. 10mA
 Minimum adjustment: 0-1.6V DC

Date: 09/01-2025
 Drawn by: JEH/DF
 Document No.: 950-205221_EC-POT-S_ECMOTOR_ES946
 Rev.: 2.1
 Manufacturer: **LS Control A/S**, Industrivej 12, DK-4160 Herlufmagle



QR-Code for download of this product sheet.

