

User Manual



PressureBox



PressureBox Highlights

PressureBox has 3 different areas of usage

1. Only showing the measured value
2. As external transducer in installations
3. As regulator with build-in transducer

PressureBox is available in 4 major pressure areas which can be scaled

0-7000Pa - can be scaled to 0-5000Pa, 0-3000Pa or 0-2000Pa

0-2500Pa - can be scaled to 0-1500Pa, 0-500Pa or 0-250Pa

0-500Pa - can be scaled to 0-250Pa, 0-125Pa or 0-50Pa

0-50Pa - cannot be scaled

Each of the major pressure area models are also available in the variants

1 or 2 build-in pressure transducers

With or without display

More PressureBox models have the possibility for connecting 2 temperature sensors of type NTC or PT1000

For all models signal output can be chosen to be ModBus or 0-10V / 4-20mA.

Please also refer to model overview on page 5.

Content

Safety Precautions	p.	3
Standards and Directives	p.	4
Model Overview	p.	5
Technical Specification and Measures	p.	6
Connection Diagram and Jumpers	p.	7
Choice of pressure area	p.	9
Setting-up the PressureBox via Display	p.	11
Functionality	p.	13
Menu in PressureBox Display	p.	14
ModBus Protocol	p.	15

This manual is primarily to be used by technicians whom are to set-up and use the PressureBox in an installation.

It posits that personnel installing this product are in possession of necessary practical experience and education within the area the product is to be used and also hold necessary authorizations to install installation materials.

Safety Precautions

- Please read the entire manual before installing and using the PressureBox.
- In case the instructions in this manual are not followed it may harm the product and suspend any guarantee.



Be careful not to harm the product during unpacking.



Be sure to follow rules for tools when mounting.



Do not touch product with wet hands.



Do not store or use product outside recommended temperature area, and do not expose it to UV-light.



Do not wash product with water or any other liquids.



Product is only to be used in non-condensing environment.



Product must not be exposed to direct sunlight.



Make sure to be ESD-discharged before operating the buttons under the lid.



Product must not be disposed of in refuse collection.

Product must be disposed of according to local regulations regarding disposal of small electronic products.



Manufacturer

LS Control A/S
Industrivej 12, Gelsted
4160 Herlufmagle
Denmark

+45 5550 5550

isc@lscontrol.dk

Standards and Directives

PressureBox complies to below standards and directives.

- EN60335-1:2012 - Household and similar electrical appliances (LDV) - safety - Part 1: General requirements.
- EN60335-1/AC:2014 - Household and similar electrical appliances (LDV) - safety - Part 1: General requirements.
- EN 61000-6-1:2019 - Electromagnetic compatibility (EMC) - Part 6-1: Generic standards - Immunity standard for residential, commercial and light-industrial environments.
- EN 61000-6-3:2007 - Electromagnetic compatibility (EMC) - Part 6-3: Generic standards - Emission standard for residential, commercial and light-industrial environments.
- EN 61000-6-3/A1:2011 - Electromagnetic compatibility (EMC) - Part 6-3: Generic standards - Emission standard for residential, commercial and light-industrial environments.
- EN 61000-6-3/A1/AC:2012 - Electromagnetic compatibility (EMC) - Part 6-3: Generic standards - Emission standard for residential, commercial and light-industrial environments.



This product complies to RoHS directive, Directive 2011/65/EU

The manufacturer of this product is a member of the compulsory recycling system under the WEEE directive

Model overview

Product Number	Product Name	Display Yes/No	NTC / PT1000 inputs	Number of transducers	Pressure Area in Order	Factory Setting
40745	PressureBox ED 50 /ES 1088	Yes	2	1	0-50Pa	0-50Pa
40747	PressureBox ED 500 /ES 1088	Yes	2	1	0-50Pa 0-125Pa 0-250Pa 0-500Pa	0-500Pa
40748*	PressureBox Dual E500 24DC /ES 1088 ModBus only	No	0	2	0-500Pa	0-500Pa
40760	PressureBox E 2500 /ES 1088	No	0	1	0-250Pa 0-500Pa 0-1500Pa 0-2500Pa	0-500Pa
40761	PressureBox E 2500 (0-500) /ES 1088 0-10V only	No	0	1	0-250Pa 0-500Pa 0-1500Pa 0-2500Pa	0-500Pa
40765	PressureBox E 7000 /ES 1088	No	0	1	0-2000Pa 0-3000Pa 0-5000Pa 0-7000Pa	0-7000Pa
40770	PressureBox Dual E 2500 /ES 1088	No	0	2	0-250Pa 0-500Pa 0-1500Pa 0-2500Pa	0-500Pa
40775	PressureBox Dual E 7000 /ES 1088	No	0	2	0-2000Pa 0-3000Pa 0-5000Pa 0-7000Pa	0-7000Pa
40780	PressureBox ED 2500 /ES 1088	Yes	2	1	0-250Pa 0-500Pa 0-1500Pa 0-2500Pa	0-500Pa
40785	PressureBox ED 7000 /ES 1088	Yes	2	1	0-2000Pa 0-3000Pa 0-5000Pa 0-7000Pa	0-7000Pa
40790	PressureBox Dual ED 2500 /ES 1088	Yes	2	2	0-250Pa 0-500Pa 0-1500Pa 0-2500Pa	0-500Pa
40798	PressureBox Dual ED 7000 /ES 1088	Yes	2	2	0-2000Pa 0-3000Pa 0-5000Pa 0-7000Pa	0-7000Pa

*** Note:**

Item number 40748 is equipped with ModBus **only**. No 0-10V output nor digital input is available.
Item number 40761 is equipped with 0-10V output **only**. No ModBus nor digital input is available.

Technical Specifications

Supply Voltage:	24V AC/DC $\pm 15\%$
Power Consumption:	Less than 200mA
Enclosure:	IP54
Weight:	200 g
Storing Temperature:	+5°C to +50°C non-condensing
Humidity:	0-97%RH non-condensing

Operating Temp for models with display	
24VAC:	0°C to +35°C
24VDC:	0°C to +40°C non-condensing

Operating temp. for models without display	
24VAC:	-20°C to +35°C
24VDC:	-20°C to +50°C non-condensing

Temperature Sensor Input: 2 x NTC10K / PT1000

NTC Temp. Sensor Area: -30°C til +130°C
Accuracy: $\pm 1^\circ\text{C}$

Pt100 Temp. Sensor Area: -80°C til +80°C
Accuracy: $\pm 0,5^\circ\text{C}$

Pressure Hose Connection: \varnothing 4mm

Pressure Area: 0-7000Pa
Pressure Accuracy: $\pm 1,5\%$ of measured value, $\pm 10\text{Pa}$

Pressure Area: 0-2500Pa
Pressure Accuracy: $\pm 1,5\%$ of measured value, $\pm 3\text{Pa}$

Pressure Area: 0-500Pa
Pressure Accuracy: $\pm 0,75\%$ of measured value, $\pm 0,15\text{Pa}$

Pressure Area: 0-50Pa
Pressure Accuracy: $\pm 0,75\%$ of measured value, $\pm 0,04\text{Pa}$

For accuracy of pressure it is required that pressure sensor is zero-calibrated. The 0-50Pa and 0-500Pa models are zero-calibrated from factory.

Communication Protocol: ModBus
Communication Interface: RS485

Size and Measures

Front

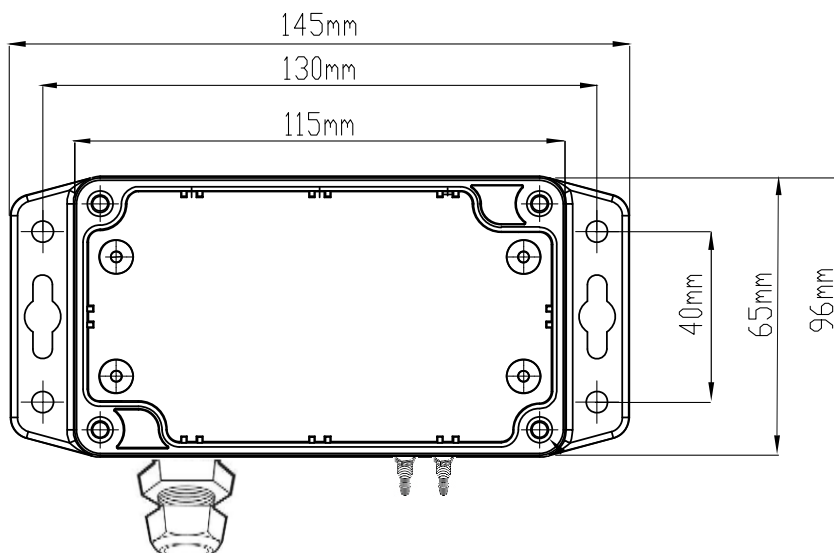

Side



Connection Diagram

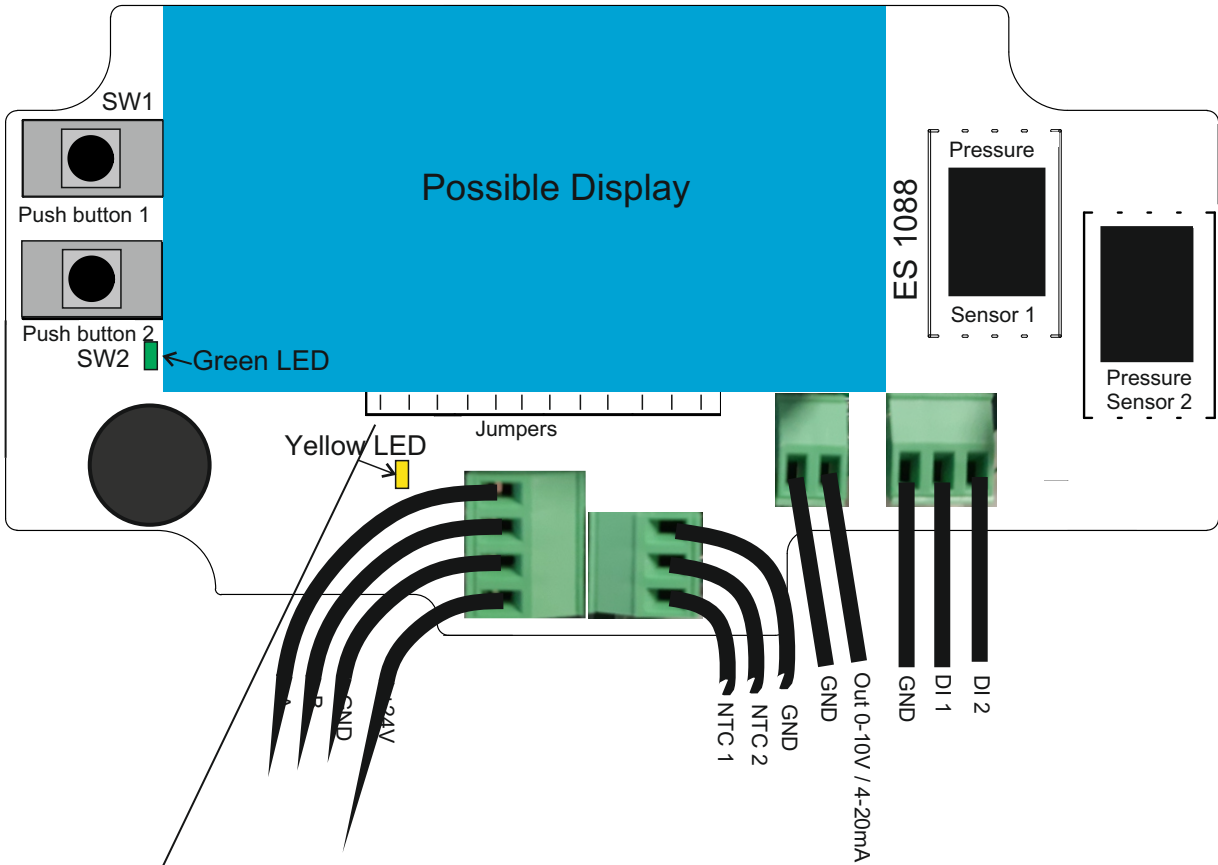

Jumper Choices

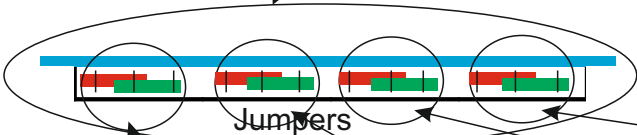

Use the jumpers to choose ModBus termination, type of temperature sensor and output V/mA. See below for selections.

- Jumper 1**
ModBus termination
█ Termination Off
█ Termination On
- Jumper 2**
NTC / PT1000
█ PT1000
█ NTC
- Jumper 3**
NTC / PT1000
█ PT1000
█ NTC
- Jumper 4**
0-10V / 4-20mA Output
█ 0-10V out
█ 4-20mA out

Jumper	2 pins at right (marked red) connected	2 pins at left (marked green) connected
1: ModBus termination	Termination OFF	Termination ON
2: NTC/PT1000	PT1000	NTC
3: NTC/PT1000	PT1000	NTC
4: V/mA output	0-10V Out	4-20mA out

Connecting Pressure Tubes

Below photos show how to connect the pressure tube to PressureBox without display. Pressure tubes are connected the exact same way on PressureBox with display.

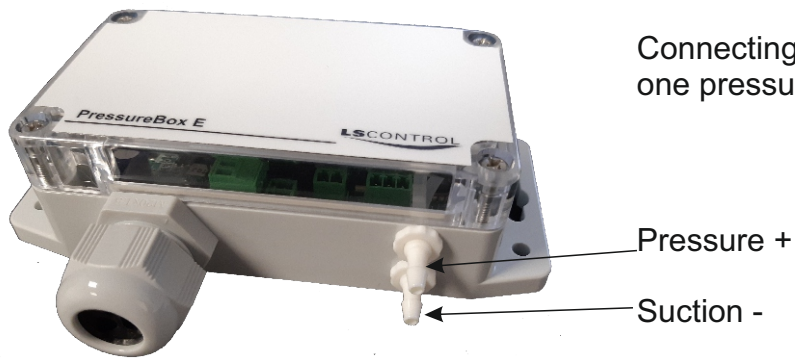

Connecting the pressure tubes on PressureBox with one pressure transducer only.

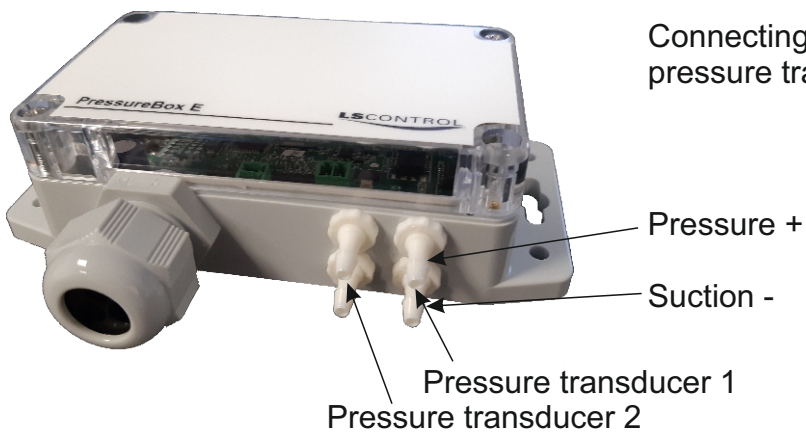

Connecting the pressure tubes on PressureBox with 2 pressure transducers.

Mounting

PressureBox must be mounted on a firm non-vibrating surface by use of screws through the holes in the mounting base on each side of the PressureBox.

Please also pay attention to the paragraph with safety precautions and preconditions for mounting and using the product.

Setting Pressure Area in PressureBox without Display

To use PressureBox as a pressure transducer in installations using 0-10V or 4-20mA signal it is possible to set most models of PressureBox to 1 of 4 different pressure areas. Please refer to table of PressureBox models to select the right model to the required pressure area. **Note:** Model 40748 PressureBox DUAL E 500 24DC cannot be set using the push buttons as this model is ModBus only and without the possibility to set different pressure area.

Below instruction shows how to change the pressure area.

Turn screws and remove lid from PressureBox. Now you have access to the push buttons and the connection clamps.

Connect supply voltage.

Hold button 1 down until the yellow LED is constantly lit. Let go of button 1.

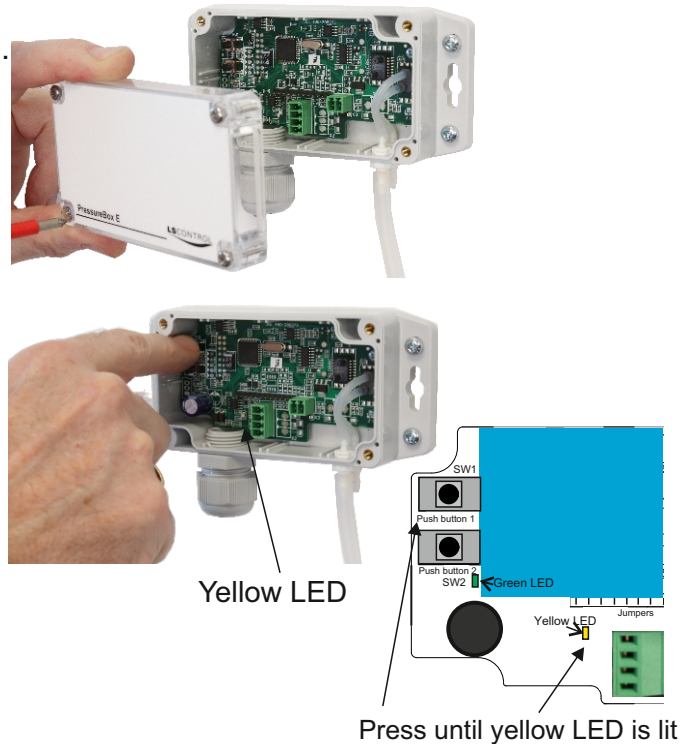

Push button 1 the number of times required for the desired pressure area. E.g. for PressureBox E 2500 (0-500; 1 time for 0-250Pa, twice for 0-500Pa, 3 times for 0-1500Pa and 4 times for 0-2500Pa.

When no buttons have been pushed for 10 sec. or by pushing button 2, the PressureBox saves the selected pressure area and yellow LED turns off.

The PressureBox is now ready to be used as pressure transducer, where pressure is read as 0-10V or 4-20mA signal through the analogue output.

The green LED flashes the number of times you have pushed button 1 and thereby indicate the setting. 2 flashes followed by pause, then again 2 flashes indicates a setting of 0-500Pa.

If by mistake an erroneous pressure area has been chosen. The procedure needs to be repeated by first pushing button 2 shortly and then button 1 until yellow LED is constantly lit.

If you want to read the pressure though ModBus you must also set the Pressure Area using ModBus Protocol.

Please see the paragraph on setting up PressureBox using ModBus Protocol.

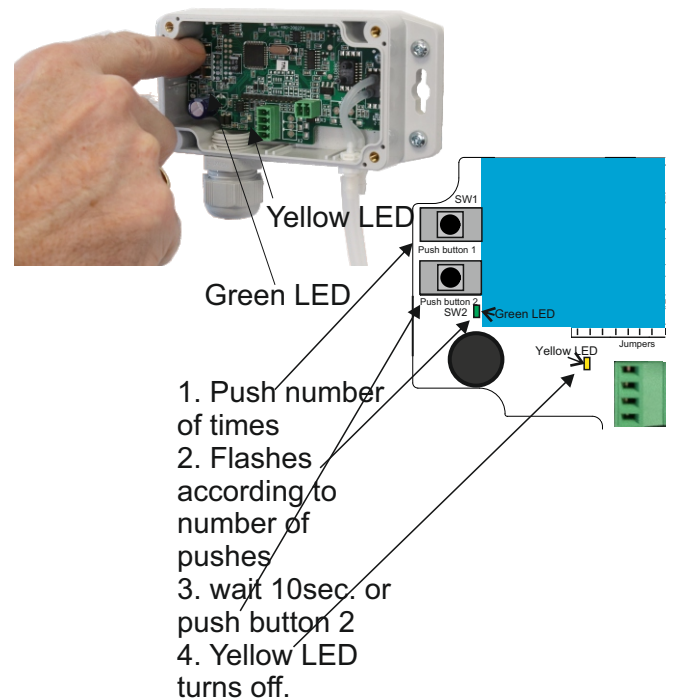

Recalibration / Reset of PressureBox Without Display

PressureBox is calibrated from manufacturer. If however, despite of that it is necessary to recalibrate / reset the pressure, it can be performed as described below.

Only PressureBox models with pressure area 0-2500Pa og 0-7000Pa can have the presure recalibrated / reset.

PressureBox 0-500 and 0-50 is equipped with another pressure sensor. These models cannot be recalibrated or have pressure reset manually.

Turn screws and remove lid from PressureBox. Now you have access to the push buttons and the connection clamps.

Connect supply voltage.

Push button 2 and hold till green LED flashes very fast

Keep hold pressure to button 2 till green LED turns off

Keep hold pressure to button 2 till green LED again turns on and is constantly lit.

Let go of button 2

PressureBox is now recalibrated, pressure reset.

If your PressureBox is equipped with 2 pressure sensors, both sensors are recalibrated / reset at the same time (going through above procedure once).

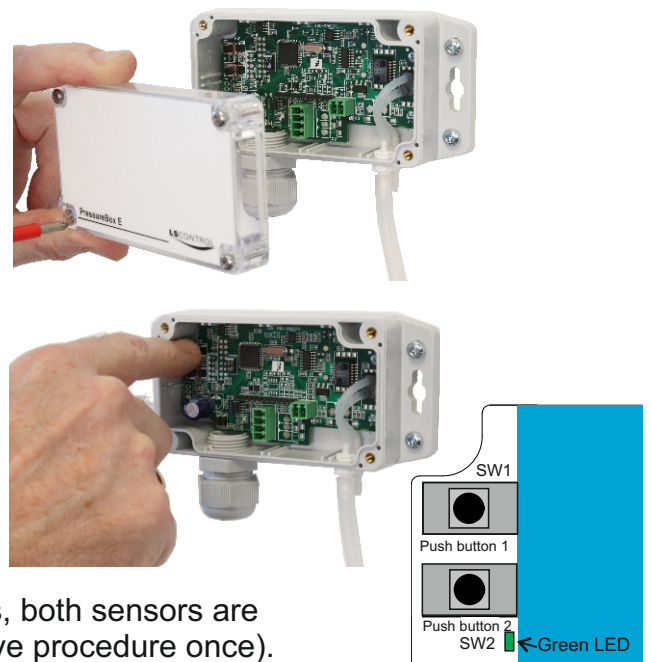

Recalibration / Reset of PressureBox With Display

PressureBox with display is calibrated from manufacturer. If it despite that is necessary to recalibrate / reset the pressure in PressureBox with display, it can be done using menu point 24.ZERO.

Only the PressureBox models with pressure area 0-2500Pa og 0-7000Pa can have the pressure recalibrated / reset.

PressureBox 0-500 and 0-50 is equipped with another pressure sensor. These models cannot be recalibrated or have pressure reset manually.

Further Settings of PressureBox Without Display

If PressureBox without display is to be used in installations where K-factor, setpoints to PID-regulator etc. are to be used, it must be set using the ModBus protocol.

Please refer to the tables starting at page 12 with ModBus Protocol settings for PressureBox.

Setting PressureBox With Display

To use PressureBox as a pressure transducer in installations using 0-10V or 4-20mA signal it is possible to set most models of PressureBox to 1 of 4 different pressure areas. See table of PressureBox models for the different models possible pressure areas.

Below instruction shows how to change the pressure area.

Turn screws and remove lid from PressureBox. Now you have access to the push buttons and the connection clamps.

Connect supply voltage.



Hold down button 1 for approx. 15 sec. until display changes to show 'SCALEMAX' and the current pressure scale setting is shown.

Let go of button 1

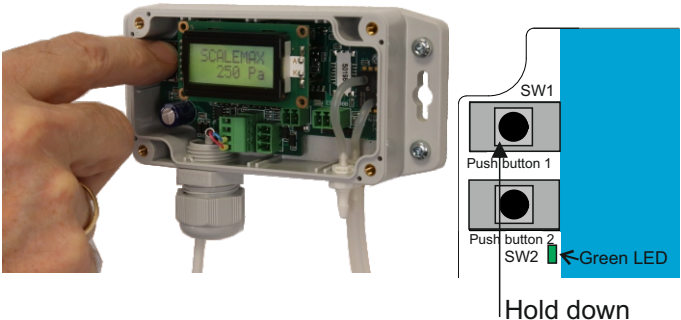

Push button 1, with each push the scale value changes in display. Stop when required scale is shown.

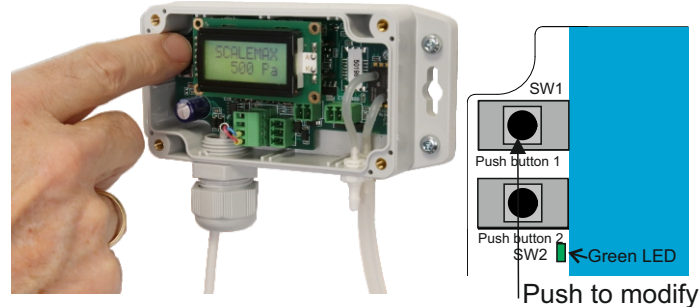

When the required scale value is shown in display, push button 2 to save the setting.

PressureBox is now ready to be used as pressure transducer, where pressure can be read as 0-10V or 4-20mA signal through the analogue output.

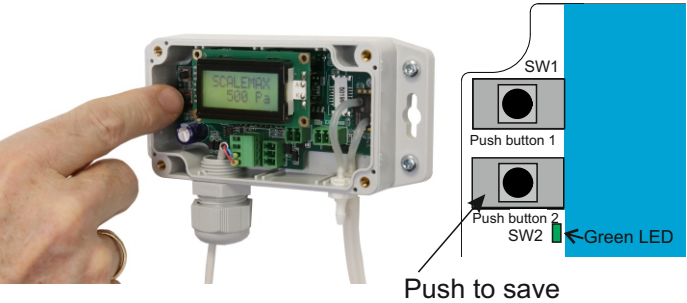

Setting up PressureBox with Display Using the Menu Setting

For PressureBox with display you can activate the PID Regulator and alarm function and alter various data / setpoints using the push buttons under the lid. The Menu settings and values are shown in the display and can be altered by pushing button 1 and 2 in turns as described below..

An overview of the menu items, their usage, possible settings and factory settings are to be found on next page.

To get to the PressureBox with display setting menu push button 2 is held down for 3 sec. until 01.SET1 shows in display. Then let go of button 2.

Now push button 2 making first digit flash. Now the first digit can be changed to value between 0-9 by pushing button 1. Value of digit changes by 1 for each push.

When required number for the first digit is reached, press button 2 to go to next digit, which starts to flash.

Repeat this procedure until all digits have the required value. When pushing button 2 after last digit is set, then setpoint value 1 is set.

To set up another menu item just push button 1 to go through the menu items. When getting to the required item repeat procedure of pushing button 2 first and then button 1 until required value is shown. Save by pushing button 2 at the end.

E.g. Menu item 23.ALTID (ALarm TIme Delay). When menu item is shown in display, push button 2 to set the value.

Then push button 1 until required value is displayed.

When required value is displayed, push button 2 to save value. You may now go through the menu items by pushing button 1.

Menu item 26.EXIT: by pushing button 2 all settings are saved and PressureBox will work as set up and returns to displaying current data points.

If no buttons are pushed for 25sec. PressureBox saves the entered settings, leave the setting menu and turn off background light.

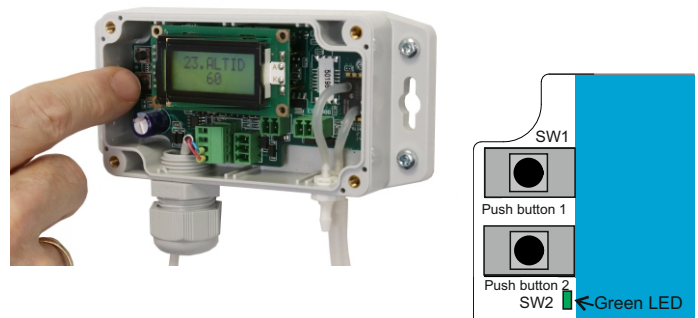
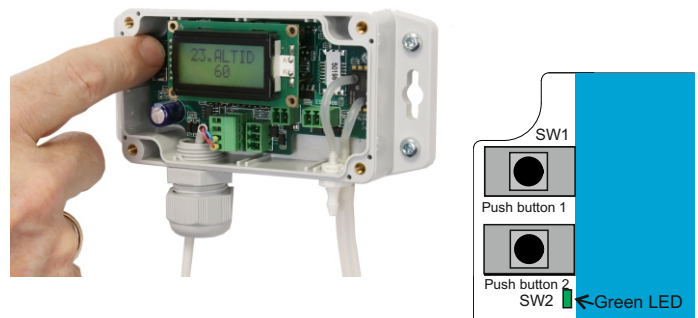
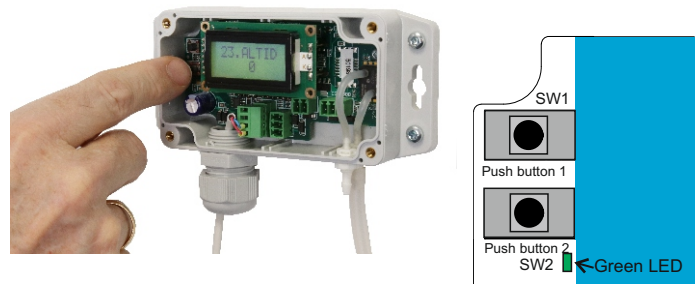
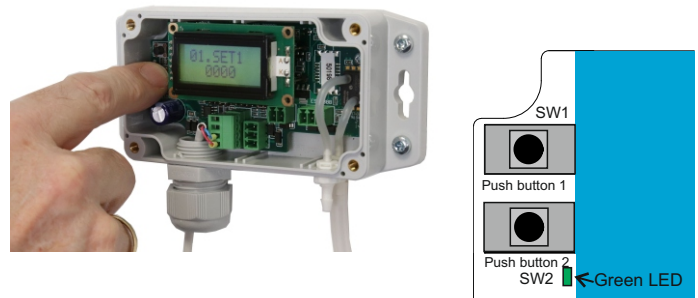

Functionality

PressureBox can be used as a very simple transducer, which only measure pressure and display it in either display or ModBus. It can also be used as an external sensor which sends the measured pressure to an external controller through 0-10V, 4-20mA output or ModBus. Finally PressureBox can function as a controller with build-in transducer. The required functionality is chosen either in menu item 03:MODE or ModBus address 4x0002. Refer to below table for description of chosen parameter according to function.

Value	Description
OFF=Pa	Current pressure is displayed in Pa in display or ModBus.
OFF=l/s	Current value for liter air per second is displayed in display or ModBus. To get the correct value the K-factor value of the used pipes must be entered in menu item 04.K VAL or ModBus address 4x0003 and 4x0004.
OFF=m3h	Current value for m3 air per hour is displayed in display or ModBus. To get the correct value the K-factor value of the used pipes must be entered in menu item 04.K VAL or ModBus address 4x0003 and 4x0004.
NONE=Pa	Current pressure is displayed in Pa in display or ModBus. And is sent as regulation signal 0-10V, 4-20mA or via Modbus to external controller. 0-10V or 4-20mA is chosen on jumper 4. See jumper setting.
NONE=l/s	As OFF=l/s. Besides regulation signal is sent as 0-10V, 4-20mA or via Modbus to external controller. 0-10V or 4-20mA is chosen on jumper 4. See jumper setting..
NONE=m3h	As OFF=l/s. Besides regulation signal is sent as 0-10V, 4-20mA or via Modbus to external controller. 0-10V or 4-20mA is chosen on jumper 4. See jumper setting..
PID=Pa	PressureBox functions as controller based on pressure measured in Pascal.
PID=l/s	PressureBox functions as controller based on measured liter air per second. To regulate properly the K-factor value of the used pipes must be entered in menu item 04.K VAL or ModBus address 4x0003 and 4x0004.
PID=m3h	PressureBox functions as controller based on measured m3 air per hour. To regulate properly the K-factor value of the used pipes must be entered in menu item 04.K VAL or ModBus address 4x0003 and 4x0004.

PressureBox is also equipped with a build-in Alarm function, where minimum and maximum values for alarm can be entered. As the alarm function sets a data point to 1 at alarm, the Pressure is, when connected to our gateway-solution, able to send alarmmessages on e.g. a mobile phone.

Table of Menu Setting, Data Points, Usage, Factory Setting

Name in Display	Description	Value	Factory Setting
01.Set1	Regulation value when digital input 1 is disconnected	Depending on model	0
02.Set2	Regulation value when digital input 1 is connected	Depending on model	0
03.MODE	Choose amongst PID Regulator, signal or show only. OFF=Pa, OFF=l/s, OFF=m3h, NONE=Pa, NONE=l/s, NONE=m3h, PID=Pa, PID=l/s, PID=m3h	OFF=Pa - PID=m3h	OFF=Pa
04.K VAL	Set value for K-factor constant	000.000 - 199.999	1.0
05.PIDKP	Set PID regulator value for KP (Regulator amplification. Should not be changed)	0-100	10
06.PIDTI	Set PID regulator value for TI (Integration time for regulator. Should not be changed)	0-1000	500
07.PIDH	Set PID regulator value for H (Sampling speed of regulator. Should not be changed)	1-1000	500
08.PIDST	Set PID regulator value for ST (regulating frequency in seconds)	0-10	1
09.OUTMI	Set minimum value for analogue output in %, when PIDreg is ON	0-100,0%	0,0%
10.OUTMA	Set maximum value for analogue output in %, when PIDreg is ON	0-100,0%	100,0%
11.SENS1	Set type of temperature sensor connected to input1 Note: Jumper setting must be identical to sensor choice in ModBus	NONE, PT1000, NTC10K	NONE
12.SENS2	Set type of temperature sensor connected to input2 Note: Jumper setting must be identical to sensor choice in ModBus	NONE, PT1000, NTC10K	NONE
13.ADDRE	Set ModBus address	1-247	1
14.BAUD	Set ModBus baudrate	9600, 19200	19200
15.PARIT	Set ModBus parity bit	NONE, ODD, EVEN	EVEN
16.MINPA	Set Value for Pa		0
17.MINOU	Set minimum value for analogue output in %, when PIDreg is OFF	0-100,0%	0,0%
18.MAXPA	Set maximum value for Pa		Depending on model

Table of Menu Setting, Data Points, Usage, Factory Setting, continues

Name in Display	Description	Values	Factory Setting
19.MAXOU	Set min. value for analogue output in %, when PIDreg is OFF		100,0%
20.ALAKV	Set alarm function	ALARM OFF, ALARM DIS	OFF
21.ALMIN	Set min. value for alarm. Alarm is activated when value get below set value.	Depending on model	0
22.ALMAX	Set max. value for alarm. Alarm is activated when value is exceeded.	Depending on model	max pressure for model
23.ALTID	Set delay time in sec. for alarm when alarm setpoint is exceeded. ALarm TIme Delay	0-99	20
24.ZERO	Reset pressure sensor ONLY VALID FOR 2500Pa and 7000Pa models		
25.SHOW	Set display to show constant temperature (TEMP), pressure/flow (PRESSURE), digital- (DIGITAL), analog (OUTPUT) output or all in turns by choosing CYCLE.	CYCLE, TEMP, PRESSURE, DIGITAL, OUTPUT	CYCLE
26.DISPL	Background light when menu is inactive. 1=turned off, 2=dimmed, 3=illuminated	1-3	1
27.EXIT	Exit menu		

ModBus Protocol

ModBus Protocol	
Mode:	RTU
Baud	Modbus baud rate (Setpoint)
Start bits	1
Data bits	8
Stop Bits	1 stop bit at Even or Odd, 2 stop bit at None
Parity	Modbus parity (Setpoint)
Address	Modbus address (Setpoint)
Registers Map	
Support function	3, 4, 6, 17

Modbus data points

All ModBus data points are 'read only'. Below table show data points in PresssureBox ES 1088, Software version 1.

Name	Unit	Value Min/Max	Modbus Address	Type	Number of decimals
NTC1 Raw			3x0000	uint16_t	0
NTC2 Raw			3x0001	uint16_t	0
Temp NTC1	°C	-30 - +130	3x0002	int16_t	0
Temp NTC2	°C	-30 - +130	3x0003	int16_t	0
PT1000 1 Raw			3x0004	uint16_t	0
PT1000 2 Raw			3x0005	uint16_t	0
Temp PT1000 1	°C	-30 - +130	3x0006	int16_t	0
Temp PT1000 2	°C	-30 - +130	3x0007	int_16t	0
Tryk Sensor 1	Pa	0-7000 model choice	3x0008	int16_t	0
Tryk Sensor 2	Pa	0-7000 model choice	3x0009	int16_t	0
Tryk Sensor LMI1	Pa		3x0010	uint16_t	0
Tryk Sensor LMI2	Pa		3x0011	uint16_t	0
Tryk Sensor NPA Zero cal 1			3x0012	uint16_t	0
Tryk Sensor NPA Zero cal 2			3x0013	uint16_t	0
AN1 Input			3x0014	uint16_t	0
AN2 Input			3x0015	uint16_t	0
DI1 input		On=1 Off=0	3x0016	uint16_t	0
DI2 input		On=1 Off=0	3x0017	uint16_t	0
Analog out		0-1000	3x0018	uint16_t	2
Alarm status		On=1 Off=2	3x0019	uint16_t	0
SW version			3x0119	uint16_t	1

Setpoint

ModBus setpoints can be set to be both 'read' and 'write'. The setpoints are used to configure PressureBox to function to your requirements. Below please find the list of setpoints in Software version 1.

Name	Unit	ModBus Address	Min	Max	Standard setting	Type	Decimal
Regulator point 1		4x0000	0	9999	0	uint16_t	0
Regulator point 2		4x0001	0	9999	0	uint16_t	0
Regulator mode 0=off-pa, 1=off-l/s, 2=off-m3/h 3=None-pa, 4=None-l/s, 5=None-m3h, 6=PID-pa, 7=PID-l/s, 8=PID-m3h		4x0002	0	8	0	uint16_t	0
Regulator K int		4x0003	0	100	1	uint16_t	0
Regulator K dec		4x0004	0	999	0	uint16_t	0
Regulator pid kp		4x0005	0	100	10	uint16_t	0
Regulator pid ti		4x0006	0	1000	500	uint16_t	0
Regulator pid h		4x0007	1	1000	500	uint16_t	0
Regulator pid st		4x0008	0	10	1	uint16_t	0
Analog output min	%	4x0009	0	1000	0	uint16_t	1
Analog output max	%	4x0010	0	1000	1000	uint16_t	1
Temp sensor type 1 0=none, 1=PT1000, 2=NTC10K Note: Jumper setting must be identical to sensor choice in ModBus		4x0011	0	2	0	uint16_t	0
Temp sensor type 2 0=none, 1=PT1000, 2=NTC10K Note: Jumper setting must be identical to sensor choice in ModBus		4x0012	0	2	0	uint16_t	0
Zero cal sensor		4x0013	0	1	0	uint16_t	0
Pressure Sensor NPA Zero cal1 <i>write disabled</i>		4x0014	0	65535	0	uint16_t	0
Pressure Sensor NPA Zero cal2 <i>write disabled</i>		4x0015	0	65535	0	uint16_t	0
Pressure sensor scale		4x0016	0	4	4	uint16_t	0
Passive min pa		4x0017	0	7000	7000	uint16_t	0
Passive min out	%	4x0018	0	1000	0	uint16_t	1

Setpoint

Name	Unit	ModBus Address	Min	Max	Standard-setting	Type	Decimal
Passive max pa		4x0019	0	7000	7000	uint16_t	0
Passive max out	%	4x0020	0	1000	1000	uint16_t	1
Alarm active		4x0021	0	2	0	uint16_t	0
Alarm min		4x0022	0	9999	0	uint16_t	0
Alarm max		4x0023	0	9999	0	uint16_t	0
Alarm time	sec	4x0024	0	99	0	uint16_t	0
Display light		4x0025	0	2	0	uint16_t	0
Display show 0=Cycle, 1=Temp, 2=Pressure, 3=Digital, 4=Poutput		4x0108	0	4	0	uint16_t	0
Sensor type 1 0=NC, 1=2500, 2=7000, 3=50, 4=500, 5=1250		4x0110	0	5	0	uint16_t	0
Sensor type 2 0=NC, 1=2500, 2=7000, 3=50, 4=500, 5=1250		4x0111	0	5	0	uint16_t	0
Restart unit restart=11223		4x0112	0	65535	0	uint16_t	0
Reset to factory default reset=12345		4x0113	0	65535	0	uint16_t	0
ModbusAdresse 1-247		4x0114	1	247	1	uint16_t	0
ModbusBaudrate 1=19200, 2=9600		4x0115	1	2	1	uint16_t	0
Modbus Parity 0=None, 1=ODD, 2=EVEN		4x0116	0	2	2	uint16_t	0
ModbusAllowWrite 0=No-Writing, 1=Allow write		4x0117	0	1	1	uint16_t	0